

# LX160s

Pilots manual



Version 3.03  
10.09.2004

**LX Navigation d.o.o.**

Tkalska 10 SLO 3000 Celje

+ 386 3 490 46 70

support@lxnavigation.si

+ 386 3 490 46 71

<http://www.lxnavigation.si>

## 1. Contents

<b>1. CONTENTS.....</b>	<b>2</b>
<b>2. GENERAL.....</b>	<b>5</b>
<b>3. DELIVERY.....</b>	<b>6</b>
<b>4. TECHNICAL SPECIFICATION .....</b>	<b>6</b>
<b>5. SWITCHES AND THEIR FUNCTIONS .....</b>	<b>6</b>
<b>6. LCD VARIO-INDICATOR.....</b>	<b>8</b>
<b>7. PNEUMATIC INPUTS .....</b>	<b>9</b>
<b>8. AFTER POWER ON.....</b>	<b>10</b>
<b>9. VARIO AND SPEED COMMAND (SC).....</b>	<b>10</b>
<b>10. SET-UP-MENU .....</b>	<b>11</b>
10.1. CONP (WIND COMPONENT ).....	11
10.2. DIST (DISTANCE) .....	12
10.3. TARG (LANDING PLACE ELEVATION INPUT).....	12
10.4. ALT (ALTITUDE) .....	13
10.5. RES (SAFETY ALTITUDE) .....	13
10.6. GPS-INPUT .....	14
10.7. PASS (PASSWORD).....	15
<b>11. SYSTEM SETUP.....</b>	<b>15</b>
11.1. POL (POLAR) .....	15
11.2. POL A,B,C,(USER DEFINED PARAMETERS).....	16
11.3. CONP (WIND CALCULATION METHOD).....	17
11.4. IND1..4 (VARIO-INDICATOR SETUP) .....	17
11.5. UNIT (UNITS).....	18
11.6. SCSP - (VARIO-SC CHANGEOVER AUTOMATIC) .....	19
11.7. TECO (TE COMPENSATION).....	19
11.8. TEFi (TE COMPENSATION FILTER) .....	20
11.9. TABS (NO AUDIO SLOT BY SC) .....	20
11.10. INT (INTEGRATION TIME OF AVERAGER) .....	20
11.11. PASS ( PASSWORD DISABLE / ENABLE, ) .....	21
11.12. SC (ON/OFF).....	21
11.13. BATT (BATTERY MONITORING) .....	21
11.14. WINPILOT/SEEUYOU MOBILE DATA STRING.....	22
11.15. FIL (USER DEFINED VARIO DUMPING INPUT) .....	22
11.16. BAL (INDIVIDUAL BALLAST INPUT) .....	22
11.17. BUGS (INDIVIDUAL POLAR DEGRADATION INPUT) .....	23
11.18. SMART VARIO (USER DEFINED SMART VARIO DUMPING INPUT) .....	23
11.19. FINAL GLIDE .....	24
<b>12. ADDITIONAL FUNCTIONS.....</b>	<b>25</b>
12.1. MEMORY INITIALIZATION .....	25
<b>13. CONFIGURATION LX 20 OR COLIBRI - LX160S - WINPILOT/CU MOBILE..</b>	<b>26</b>

---

<b>14. FAQ –" FREQUENTLY ASKED QUESTIONS" .....</b>	<b>26</b>
<b>15. APPENDIX .....</b>	<b>28</b>
15.1. MENU-STRUCTURE .....	28
15.2. WIRING .....	29
15.3. FULL CONNECTION SCHEMATIC .....	30
15.4. CUT OUT .....	31
15.5. PINING OF 15 P SUB D .....	31
15.6. REVISIONS .....	32



## 2. General

**LX160s** a modern designed vario-speed to fly director and final glide calculator, based on latest pressure transducer and microcontroller technology. Using of NMEA input will make the system even more sophisticated, and serviceable.

The unit is prepared to drive practically all PDA running navigation programs. Special data set to drive Winpilot pro and SeeYou Mobile is available. The wiring delivered with the instrument allows connecting of PDA without any problems. Using some special accessories offered by LX navigation, will make connection of PDA much simpler.

Flying without GPS input is for sure possible, using such a configuration, the pilot should input distance manually.

Like vario indicator a special custom designed LCD unit is used.

Our adress:

**LX Navigation d.o.o.**

**Tkalska 10 SLO 3000 Celje**

 **+ 386 3 490 46 70**

 **support@lxnavigation.si**

 **+ 386 3 490 46 71**

 **<http://www.lxnavigation.si>**

### 3. Delivery

- 1 x **LX160s** main unit
- 1 x **LX160s** wiring
- 1 x LCD vario indicator
- 1 x Speaker
- 1 x **LX160s** manual

### 4. Technical specification

Power input:	9-16V DC
Nominal:	12V
Consumption:	120mA / 12V ( <b>LX160</b> + LCD Vario without audio)
Temperature range:	from -10°C till +50°C
Store:	-20°C to +70°C
Weight:	
<b>LX160:</b>	310g
<b>LX160 wiring:</b>	100g
LCD Vario:	180g
Speaker:	200g
<hr/>	
Total:	790g

### 5. Switches and their functions



Fig.1 switches

ON/OFF: On/off (horizontal)



SC/VARIO/AUTO:

- SC speed command
- VARIO
- AUTO (change over vario/speed command automatic, see 9.6)



MC: (key)

MC input, after pressing of MC key up (+) and down (-)  
Actual value will be shown in the **upper row** of the vario indicator for apr. 1 second. Longer activation of the key will increase increments. (normal 0.1 m/s increased 0.5 m/s)



BUGS : (switch)

- up (2) 10% of glide ratio reduction (See 9.16)
- middle no bugs
- down (1) 5% of glide ratio reduction



BALLAST: (switch)

- up maximum (2) +20% overload (See 9.15)
- middle no ballast
- down (1) +10% overload



FILTER: (Vario dumping)

- up (2) maximum (ca. 3 Sec. time constant)
- middle (FIL) low dumping (See 9.14)
- down (1) medium ( 1.5 second)



Volume: (key)

Activation will reduce or increase the volume of audio signal. Longer press will increase increments.



## 6. LCD vario-indicator

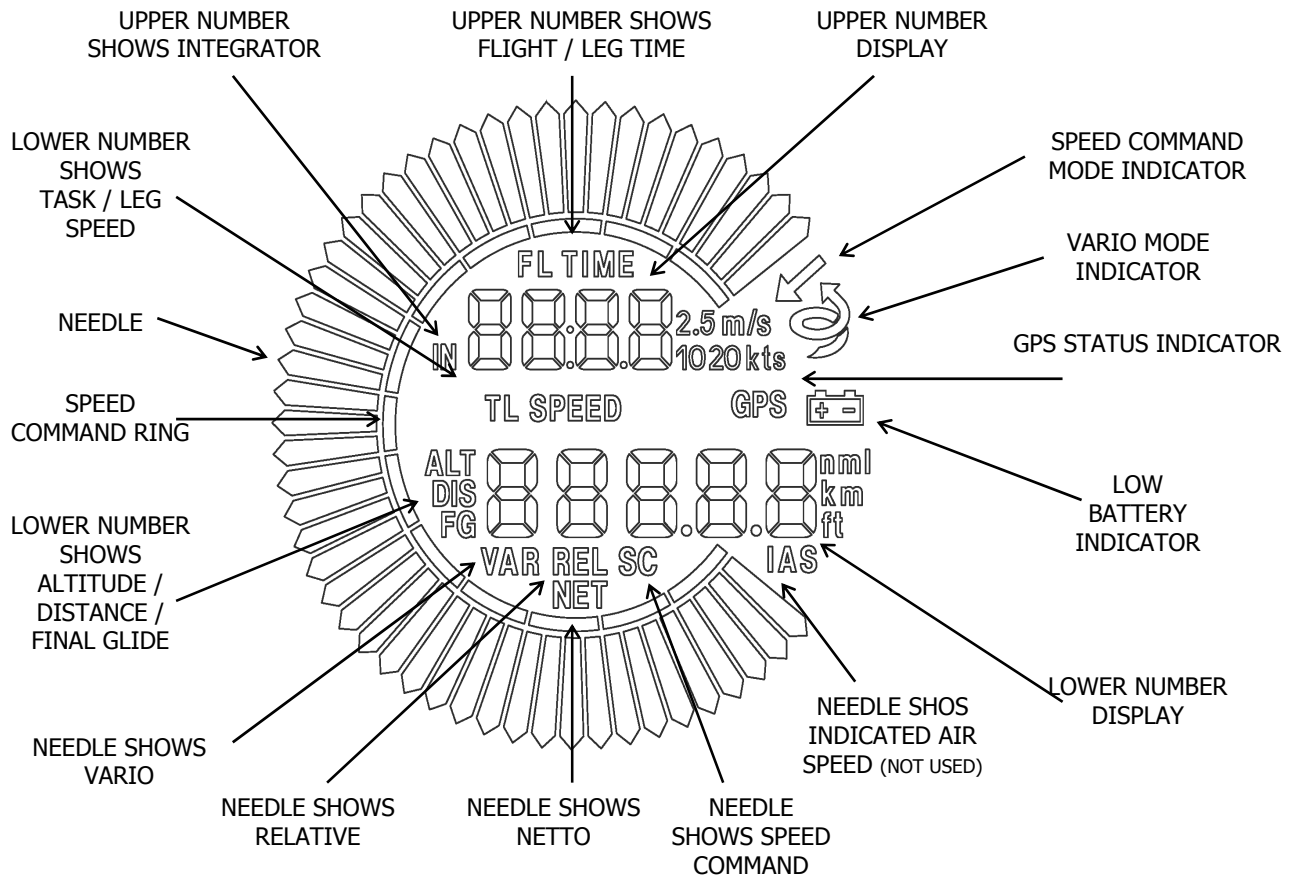

*Fig.2 LCD Vario-indicator*

LCD Vario-indicator consists of:

- vario needle
- two numeric indicators (partly programmed by pilots)
- Vario/SC status display
- SC bar (continuously)
- units and warnings

The vario indicator is an integral part of the system that means powered and controlled from the **LX160s** main unit. The connection is realized like data bus that means unlimited number of units could be connected parallel. The main unit delivers four different data strings and there fore up to four LCD vario units with different read out configuration could be used. To define the string type use DIP switches on the back side of the unit.



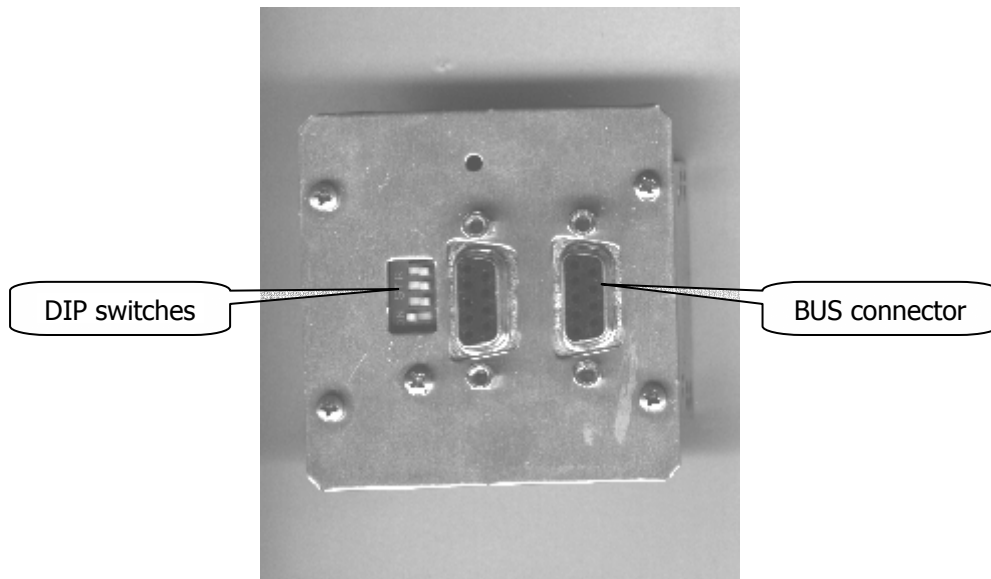

*Fig. 3 Vario-indicator back side*

Data string	switch 1	switch2	switch 3	switch 4
1	ON	OFF	OFF	OFF
2	OFF	ON	OFF	OFF
3	OFF	OFF	ON	OFF
4	OFF	OFF	OFF	OFF
prohibited	OFF	OFF	OFF	ON

For details see chapter 9.4.

## 7. Pneumatic inputs

All necessary pneumatic inlets are on the rear side of the main unit.

- **TE Pst** –Te probe, or static using electronically TE compensation.
- **Pst** Static for speed measuring
- **Ptot** Total pressure(Pitot) speed measuring

### Important!

No average indication during the flight, means that Pst and Ptot are connected opposite.

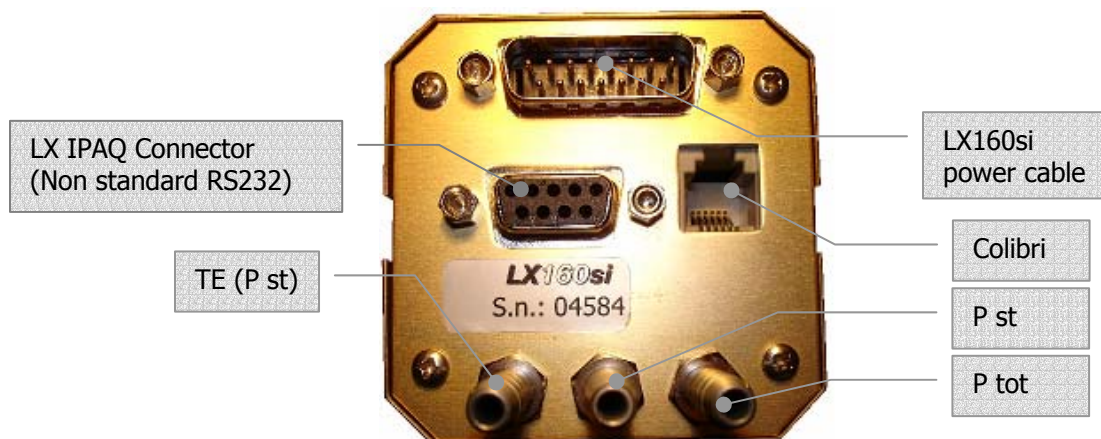
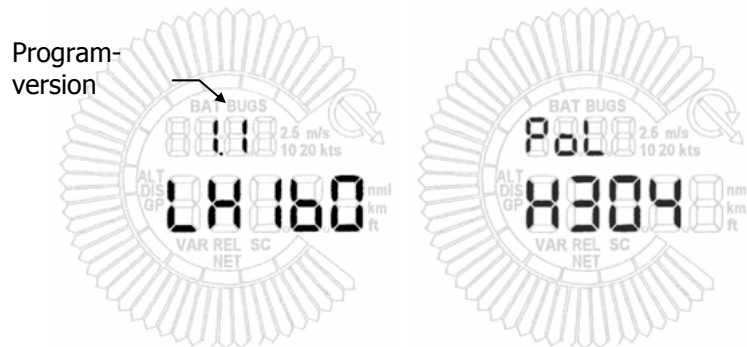

*Fig. 4 LX160si main unit rear side*

## 8. After power ON

Following screens will follow after power on:

- Program version
- Polar



*Fig 5 after power on*

## 9. Vario and speed command (SC)

Vario respectively speed command are defined by:

- external switch position
- Automatic

Some functions of LCD vario indicator are connected with status of the main unit (vario or SC). See chapter 9.4.

SC bar indicates continuously SC.

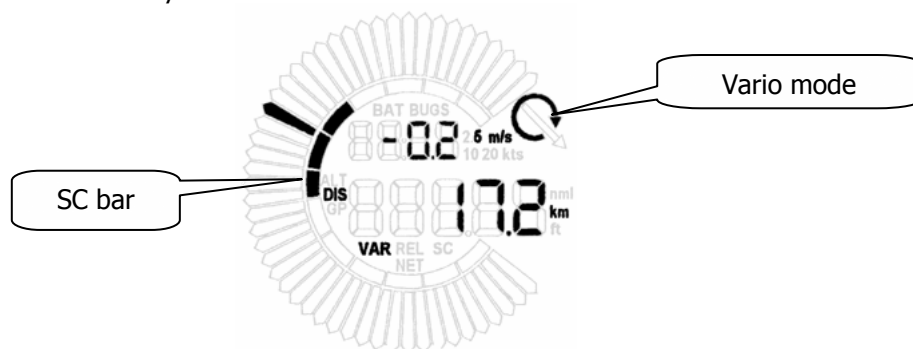

*Fig. 6 vario mode*

The mode of operation is declared using special symbols for climbing and SC mode.



*Fig. 7 SC mode*

## 10. Set-up-Menu

To step into setup menu press at the same time MC and VOL up. Individual setup menus will follow after MC + or -.

### 10.1. CONP (wind component )

The final glide calculation consider head or tail wind component. The wind component value could be input using this menu. Using GPS input an automatic wind component calculation will be active that means no manual input will be possible. The pilot is able to disable automatic wind calculation (see 9.3) using FIX method (manual input). FIX will not remain after power off.

Receiving GPS signals, GPS status indication will replace wind component indicator.

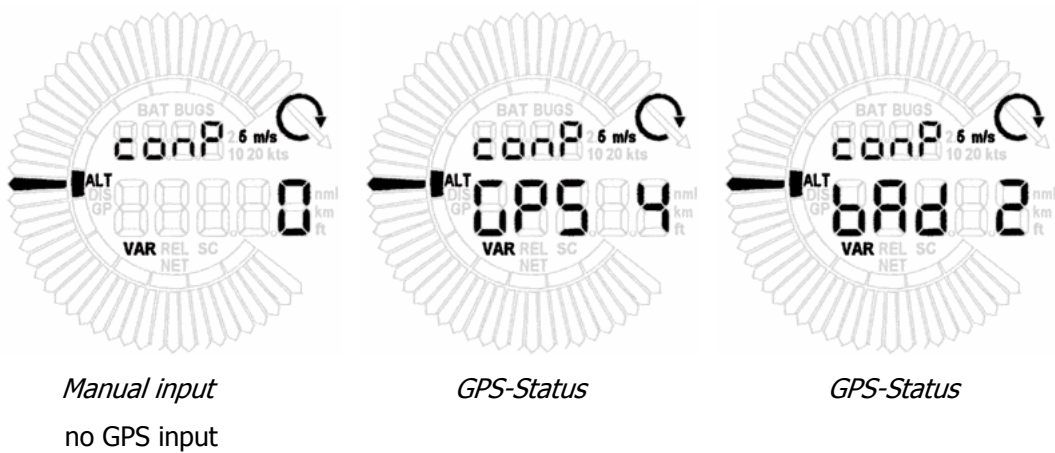

Fig. 8 wind component display

Wind component = TAS-GS

### 10.2. DIST (distance)

For accurate final glide calculation is distance the most important parameter. Using of VOL + or – will change the distance. Longer press will increase the increments (10 km).

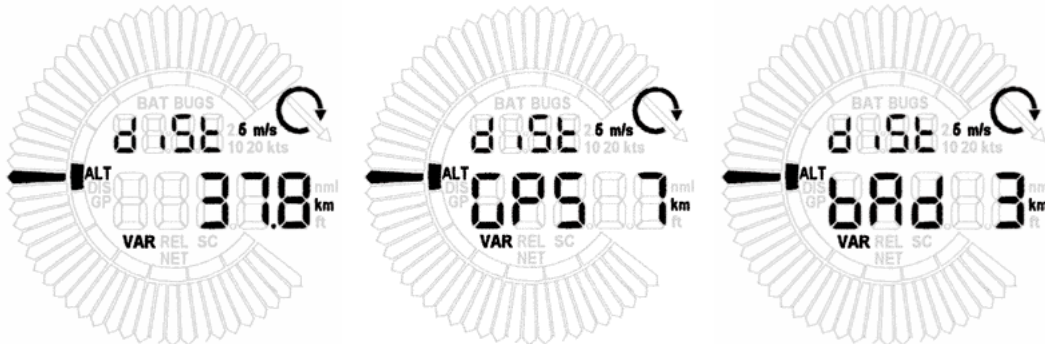

Fig 9 Distance input

The distance count down will be done automatically during the final glide. Necessary adaptations during the final glide should be done the same way like input. Using GPS input, there will be no **distance input possible**, the distance will come from GPS automatically. The distance and GPS status will be alternately present on the display.

### 10.3. TARG (landing place elevation input)

For final glide calculation is the elevation of the landing place an important parameter. The pilot should provide this input before final glide will start. Mentioned input (target) will be possible only, if the elevation of **take off airfield** has been entered like described in chapter 10.4. Otherwise (no input of take off elevation) only final glide to take off airfield will be possible.



Fig 10 Landing place elevation input (target)

**GPS will never deliver elevation of landing place, it should be done manually.**

#### 10.4. ALT (altitude)

The input 0m (no input at all), will allow final glide to the take off airfield only. The **LX160s** altimeter will show QFE altitude (0m on ground). After input of take off airfield elevation (before take off) the **LX160s** altimeter will show QNH altitude and the final glide will be possible to any airfield after "target" input. Altitude setting will remain in case that the unit has been switched off for a short time, during the flight.

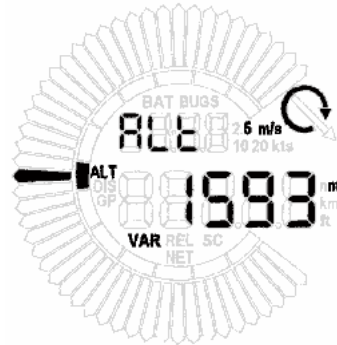

Fig 11 Set elevation

#### 10.5. RES (safety altitude)

To offset the final glide (safety reasons) use this menu. After input of safety altitude the final glide will be adequate shifted, but final glide difference indicator will **remain 0m**.

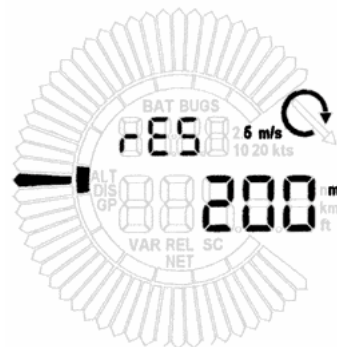

Fig. 12 safety altitude

## 10.6. GPS-input

GPS input is default active. The pilot is able to disable GPS input.



*Fig. 13 GPS input not active  
GPS data present*

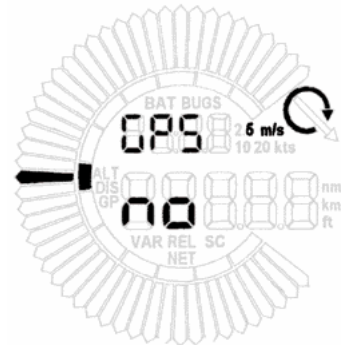

*Fig. 14 GPS data not detected*



*Fig. 15 GPS input not active  
No GPS data present*



*Fig. 16 GPS input active  
GPS data present*

Using GPS input, both the distance and wind component will be calculated automatically, no manual input through pilot possible. If the pilot wants to change wind component or distance has to deactivate GPS input obligatory (fig 13).

### 10.7. PASS (password)

After using of password further system parameters could be changed.



Fig. 17 Password

passwords:

- 04670 System set up
- 01049 "Auto Zero" (vario and speed, will take some seconds)

The individual numbers should be selected using VOL key. After some time without change of VOL key, the cursor will jump one step forward.

## 11. System Setup

### 11.1. POL (polar)

The unit has capacity to store up to 95 glider polars. The pilot has to choose his glider type from the attached library. Selection of number 0 will allow input of user defined parameters. The polar input should be done using VOL key.

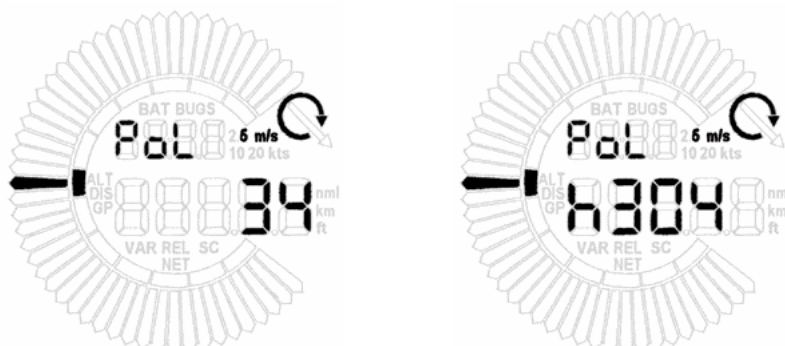
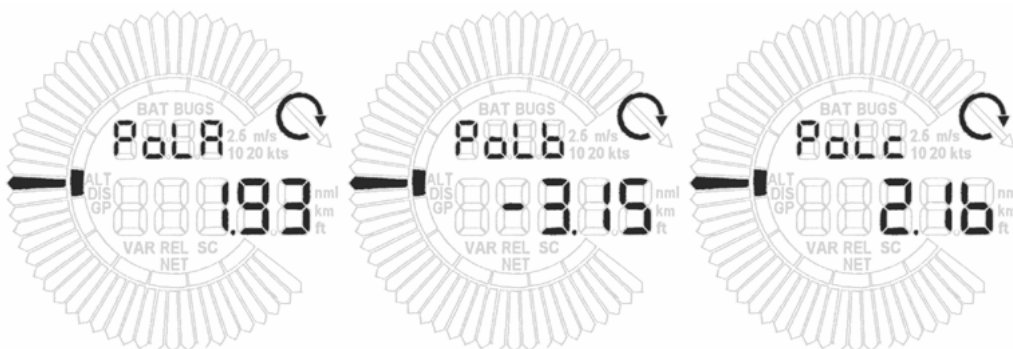

Fig. 18 Polar (number and glider type)

1 ASH 25	33 DIMONA	65 NIMBUS4D
2 ASH 25E	34 DISCUS	66 NIMBUS4T
3 ASH 26	35 DUODISC	67 NIMBUS4M
4 ASH 26E	36 G102CLUB	68 NIMB.4DM
5 ASK 13	37 G103ACRO	69 NIMB.4DT
6 ASK 21	38 H205	70 NIMBUS4M
7 ASK 23	39 H304	71 PHOEBUSA
8 ASTIR C	40 HORNET	72 PHOEBUSB
9 ASW 15	41 JANTAR2B	73 PHOEBUSC
10 ASW 17	42 JANT.ST2	74 PIK 20E
11 ASW 19	43 JANT.ST3	75 PUCHACZ
12 ASW 20	44 JANUS 3	76 S-10
13 ASW 20	45 JANUS B	77 SF26
14 ASW 22	46 JANUS C	78 SF27M
15 ASW 24	47 JANUS C	79 SF27
16 ASW 27	48 JEANSAS	80 SF34
17 CIRUS 18	49 LS 1CD	81 SPEED AS
18 CIR.L26	50 LS 1	82 CIRRUS 75
19 CIRUS ST.	51 LS 3 17	83 ST.LIBELLE
20 CL.ASTIR	52 LS 3	84 SZD 51-1
21 DG100	53 LS 4	85 SZD 53-1
22 DG200	54 LS 6	86 TWINAS 2
23 DG300	55 LS 7	87 TWINAS 1
24 DG400	56 LS 8	88 TWINAS 3
25 DG400/1	57 MININIM	89 VENTUS
26 DG500 M	58 MISTRAL	90 VENTUS
27 DG500/2	59 MOSQUIT	91 VENT.A16
28 DG500 T	60 NIMBUS2	92 VENTUS B
29 DG600	61 NIMBUS2C	93 VENT.B16
30 DG600/17	62 NIMBUS3	94 VENT.C17
31 DG800/15	63 NIMBUS3D	95 VENTUS C
32 DG800/18	64 NIMBUS4	

**11.2. POL a,b,c,(user defined parameters)**

The parameters a, b and c build a parable which is described like  $w = av^2 - bv + c$ . For a, b, and c calculation use LXpolar.exe available on [www.lxnavigation.si](http://www.lxnavigation.si).



*Fig. 19 a, b and c of user polar*

MC will search for a, b, and c and VOL will allow input.



### 11.3. ConP (wind calculation method)

Two different ways could be defined. **Auto** will calculate wind component like difference between ground speed and true airspeed (TAS-GS). **Fix** input will allow the pilot to adjust wind component by hand. The input fix will be active only one flight, after new power on, auto will be set automatically.

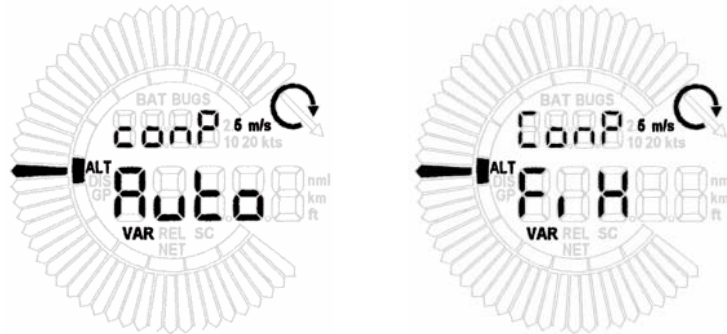

Fig. 20 Wind component calculation options

### 11.4. IND1..4 (Vario-indicator setup)

The pilot is able to adjust LCD vario indicator readings, to fulfill his individual wishes. Vario-indicator setup will offer 16 variants of settings. Table below will show the variants. It is important to accept that the settings could bring different readings for vario or SC mode. Using more LCD vario units use different DIP switch addresses to realize individual readings for each unit. There are four addresses allowed, that means up to four LCD vario units indicating different, could be used.

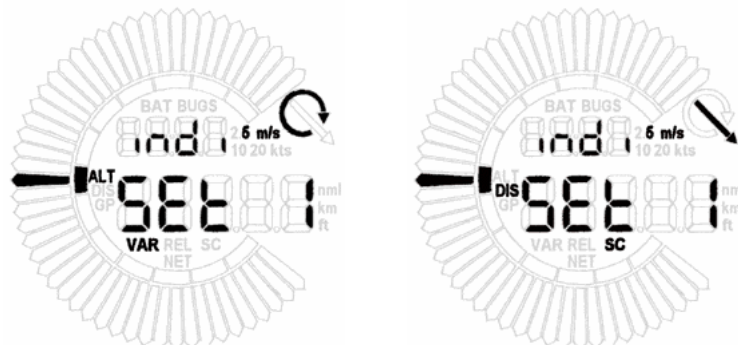

Fig 21 Vario indicator input

mode	VARIO			SC		
	needle	Lower number	Upper number	needle	Lower number	Upper number
SET0	VARIO	DIST	INT	SC	GP	INT
SET1	VARIO	GP	INT	SC	GP	INT
SET2	VARIO	DIST	INT	SC	DIST	INT
SET3	VARIO	GP	INT	SC	DIST	INT
SET4	VARIO	GP	INT	NETTO	DIST	INT
SET5	VARIO	GP	INT	RELATIV	DIST	INT
SET6	VARIO	ALT	INT	SC	GP	INT
SET7	VARIO	ALT	INT	SC	DIST	INT
SET8	VARIO	ALT	INT	VARIO	DIST	INT
SET9	VARIO	DIST	INT	SC	GP	INT
SET10	VARIO	GP	INT	NETTO	GP	INT
SET11	VARIO	GP	INT	RELATIV	GP	INT
SET12	VARIO	GP	INT	VARIO	DIST	INT
SET13	VARIO	GP	INT	VARIO	GP	INT
SET14	VARIO	ALT	INT	NETTO	ALT	INT
SET15	VARIO	ALT	INT	RELATIV	ALT	INT

- INT Averager (Integrator)
- GP Final glide deviation
- SC Speed to fly mode
- ALT Altitude (QFE,QNH depend)
- NETTO Netto vario (sinking or climbing of air mass)
- RELATIV Netto -0.7 m/s, expected climbing

**11.5. UNIT (units)**

Practically all known combinations of units could be used flying LX 160.

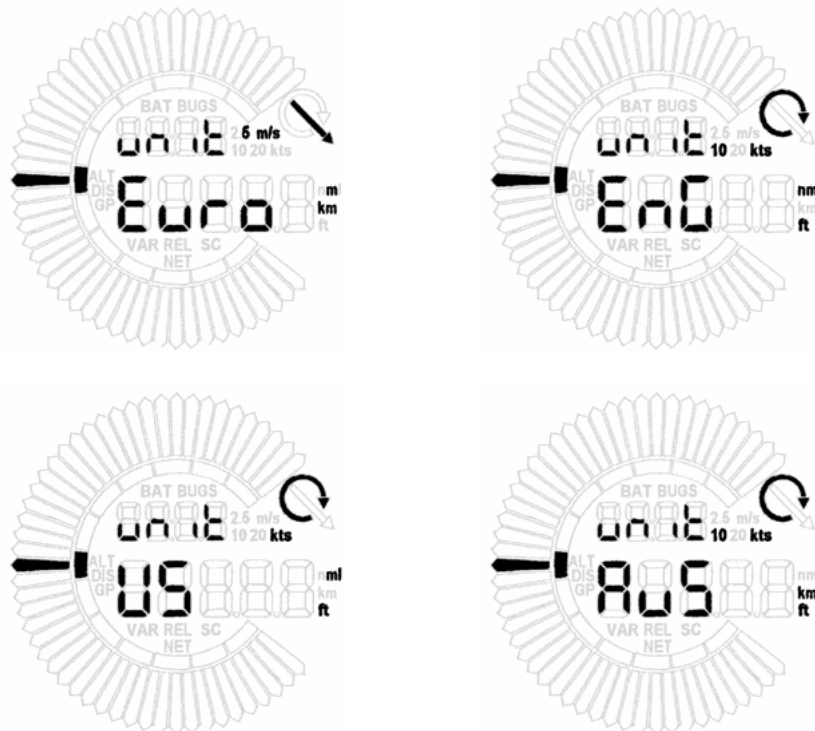

Fig 22 units

	Euro	Eng	US	Aus
altitude	m	ft	ft	m
vertical speed	m/s	kts	kts	kts
wind speed	km/h	kts	mph	kts
IAS	km/h	kts	mph	kts
distance	km	nm	mi	nm

### 11.6. ScSp - (vario-SC changeover automatic)

The input done in this menu will be active exclusively after VAR, SC, AUTO switch will be in position **AUTO**. Reaching of speed defined in this setting, the unit will change over to SC automatically and vice versa.

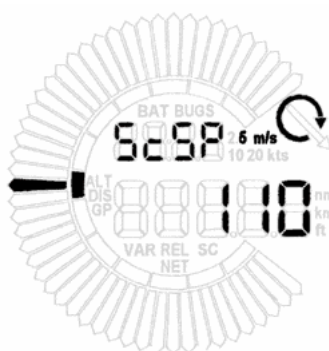

Fig. 23 Vario-SC change over automatic

### 11.7. Teco (TE compensation)

Two ways of vario TE compensation are offered, using of TE probe or electronic TE compensation. Input 0% will define TE probe and will request to connect TE Pst connector to TE probe source. Using electronically way the TE St should be brought to glider static source. It is very important to use faultless static source to be able to realize usable compensation. Default value is 100 %, having under compensated system increase the % and vice versa. One flight in calm atmosphere is requested to find the right %. Accelerate up to 160 km/h, stabilize speed and pull up till stalling. Vario deflection in + declares under compensation and opposite.

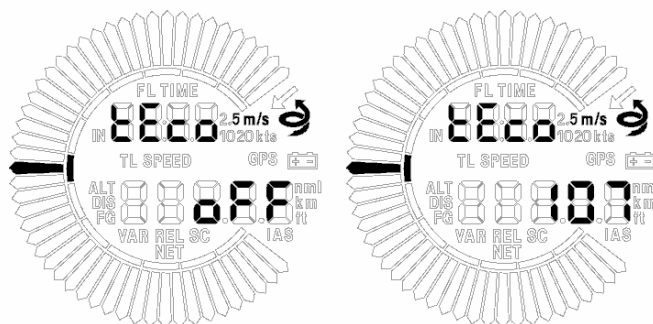
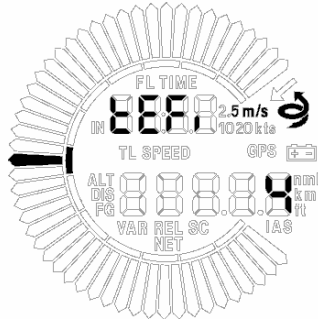

Fig. 24 TE compensation

**11.8. TEFi (TE compensation filter)**

The **TEFi** (TE filter) is the compensation delay. Larger numbers will increase the delay and vice versa. During the first test is recommended to use TEFi 4.



*Fig. 25 TE compensation filter input*

**11.9. tabS (no audio slot by SC)**

Flying in SC, the vario needle will be on zero flying correct speed, a very significant signal that the speed is correct is cut off of audio signal. The slot without audio could be adjusted by pilot using this menu.



*Fig. 26 Audio cut off slot*

**11.10. INT (integration time of averager)**

Vario averager integration time could be adjusted from 1 up to 40 seconds under pilot wishes. Factory setting is 20 seconds.

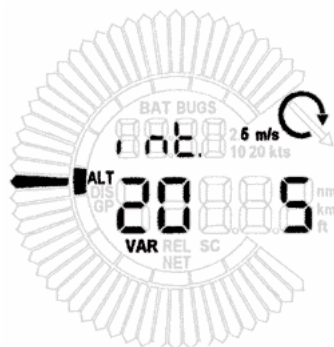

*Fig. 27 averger time input*

**11.11. PASS ( password disable / enable, )**

Disable, will disable password function during flight.

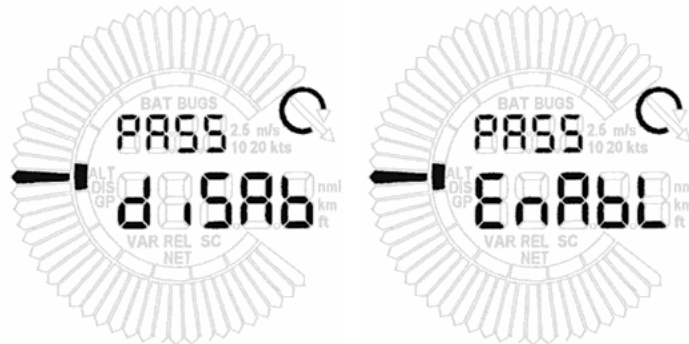

*Fig.28 Password disable / enable*

**11.12. Sc (on/off)**

Normally an external switch will be used to change over vario-SC. Active status of the switch to change over to SC (closed or open) could be defined using this menu. Factory set, ON (closed switch means SC).

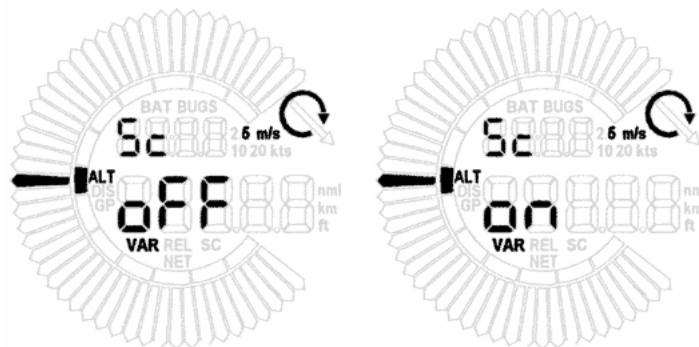

*Fig 29 SC active switch on or off*

**11.13. Batt (battery monitoring)**

No inputs expected, the battery voltage will be displayed.

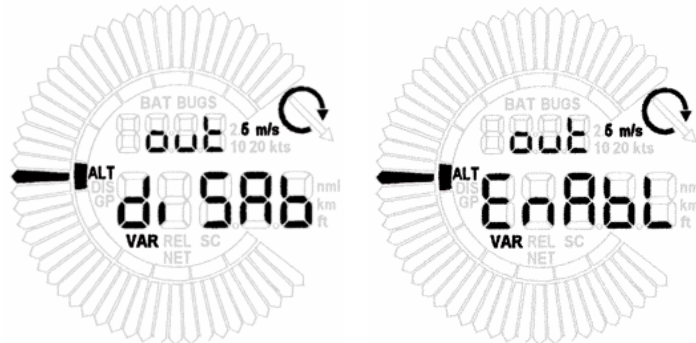

*Fig. 30 Battery voltage display*

Reaching 11V will activate an alarm, blinking of battery symbol on LCD vario.

**11.14. WinPilot/SeeYou Mobile data string**

The pilots using Winpilot/CU Mobile are obliged to activate this setting like ENABLE.



*Fig. 31 Winpilot/CU Mobile data string activation*

**11.15. Fil (user defined vario dumping input)**

On the front panel there is a switch with three positions of vario dumping. The pilot is able to define his personal time constants for all three positions separately (from 0 up to 5 seconds). The factory settings will satisfy majority of pilots.

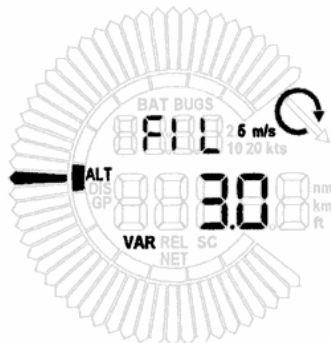

*Fig. 32 User defined vario dumping*

**11.16. Bal (individual ballast input)**

The ballast input switch has three positions. The pilots are able to define individual values of overload for each position. Overload is calculated like:

$$\text{Overload} = \frac{\text{Glider} + \text{Pilot} + \text{Ballast}}{\text{Glider} + \text{Pilot}}$$

Each position is free programmable from 1.0 up 1.5.

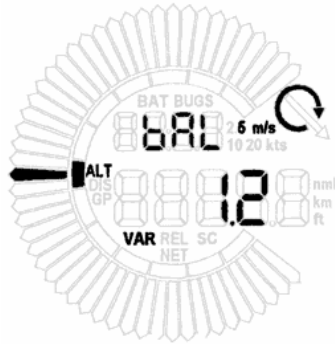

Fig 33 Individual ballast input

Overload calculating example:

Glider: 280 kg  
 Pilot: 80 kg  
 Ballast: 90 kg

$$\text{Overload} = \frac{280\text{kg} + 80\text{ kg} + 90\text{ kg}}{280\text{ kg} + 80\text{ kg}} = 1.25$$

**11.17. Bugs (individual polar degradation input)**

The pilot is able to input polar degradation (% of glide ratio reduction) instead of muddy wings like his personal settings. The default values will satisfy majority of the pilots.



Fig. 34 Individual polar degradation input

**11.18. Smart vario (user defined smart vario dumping input)**

Gives five levels of dynamic damping of the vario indication and off.

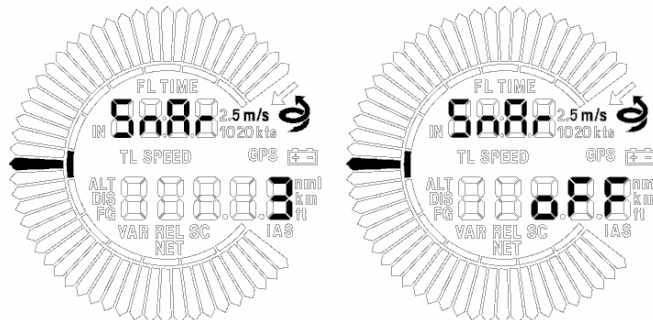
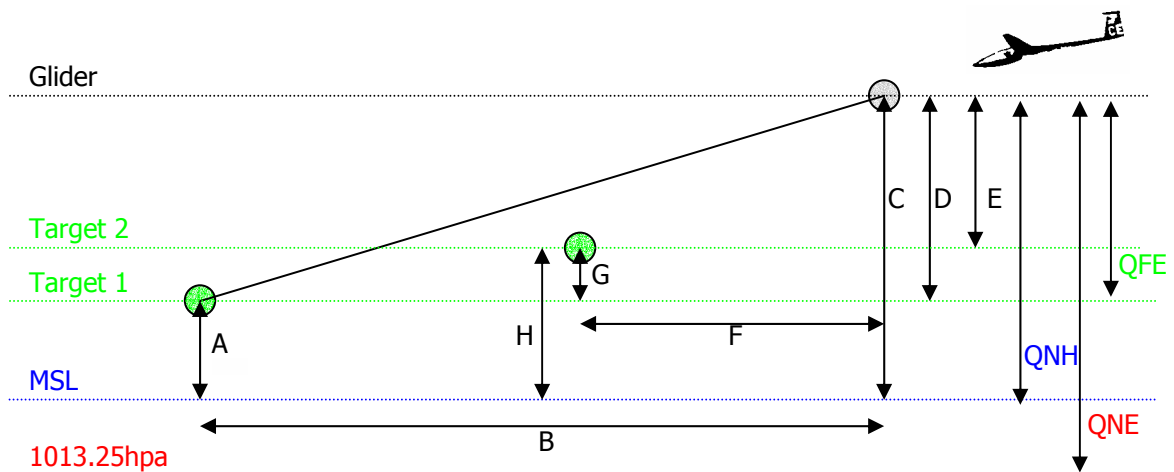

Fig. 35 Smart vario filter input

**11.19. Final glide**



*Fig 36 Final glide*

Following paramerts will influence on final glide:

- Distance
- Mc input
- Wind component
- Polar and degradation
- Safety altitude

The final glide calculator shows altitude difference (m or feet) to the ideal final glide. + indication means the glider is above the final glide and vice versa.

Flying without GPS, the pilot have to input the distance manually and to control the distance during the final glide, using a map.

**Important!**

Never forget to select finish point on GPS, before final glide. The distance will be given from GPS, if wrong selected an inadequate distance will be taken in calculation. The GPS will never deliver elevation of finish, should be input manually.



Example 1: final glide without elevation input before take off

Using this solution only final glide to **take off airfield** will be possible, **no target** input during the flight will be allowed, that means should remain on 0. The altitude indication will indicate QFE altitude.

Example 2: final glide after set elevation input

After input of **take off elevation**, final glide to believable point will be possible. The input should be done manually after power on. The altimeter of **LX160s** will show QNH altitude in that case.

Before final glide is obligatory to input elevation of (target) landing place in any way, even before final glide to the take off airfield.

**Important!**

Select the right point on GPS.

Take a look on Fig. 10.

## 12. Additional functions

### 12.1. Memory initialization

In case of some anomalies, strange characters..., provide data init memory procedure.

- **LX160s** off
- VOL und MC down,
- **LX160s** on,
- Release both switches.

**Data init** message will be present for a short time.

All settings will be set to factory **default**.



Fig. 37 Data init procedure

### 13. Configuration LX 20 or Colibri - **LX160s** - WinPilot/CU Mobile

General rules

- **LX 20 or Colibri deliver to LX160s NMEA-data (GGA,RMC and RMB) via NMEA input (never activate Winpilot data sentences)**
- **LX160s delivers NMEA+Winpilot/CU Mobile specific data to Winpilot/CU Mobile.**

All necessary cables are delivery included.

### 14. FAQ – " frequently asked questions"

Q: LCD-Vario indicates no 485?



Fig. 38

A: No data exchange - **LX160s** , LCD Vario, check cable LX 160-LCD vario

Q: No GPS data detected

A: Check, if GPS connection is OK

Q: No averager indication during the flight, vario needle very slow

A: Pst und Ptot connected opposite

Q: After power on CS-err-massage will appear



Figure 39

A: EPROM fault, send to the workshop

Q: Vario indicator is slightly out of zero

A: Use password 01049 and provide auto zero procedure

Q: Your glider is not in the library

A: Use LXe, calculate the parameters and input them like user.

Q: Winpilot/CU Mobile configuration?

A:

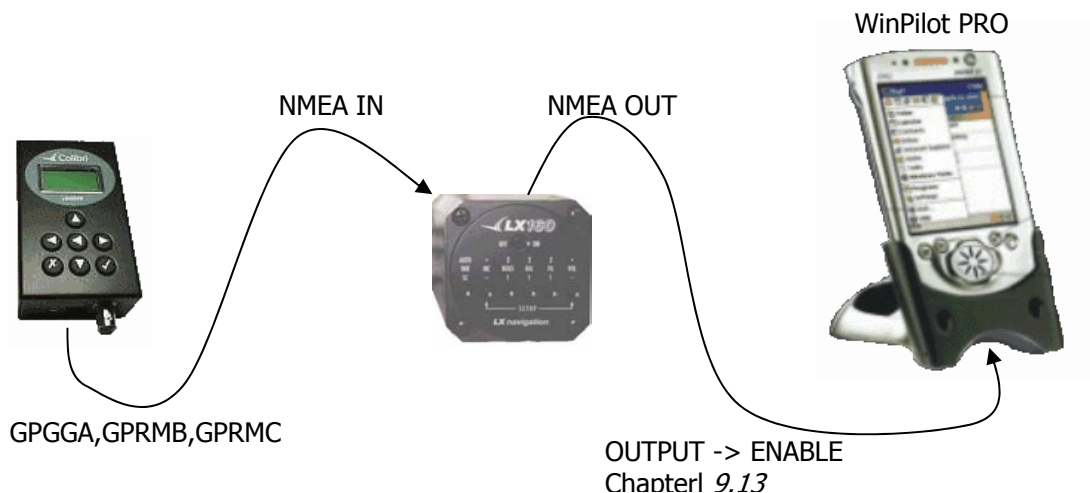

Q: What does the needle display in SC :

A:

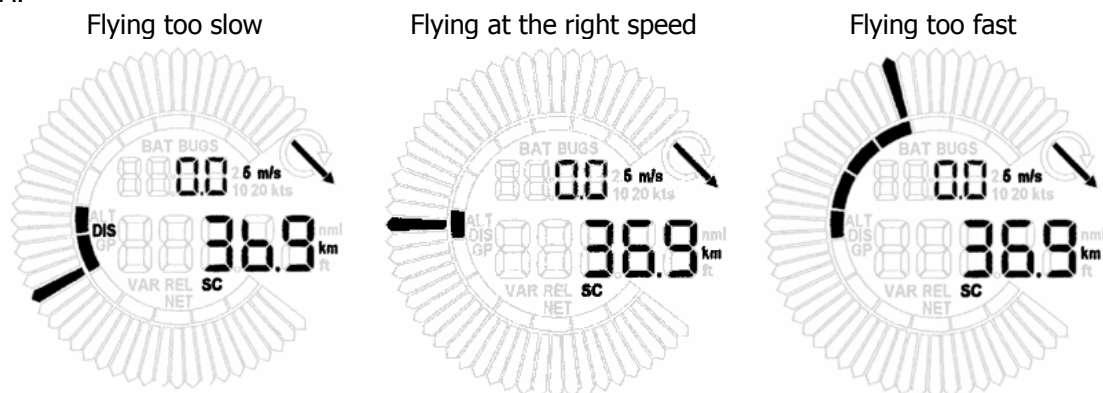

Q: Is there any way to update the FW by customer?

A: Yes, after order of EPROM by producer.

Q: If airspeed is not present average remains on 0.0.

A: Check if **Ptot** probe is connected properly. It should be connected to »**NOSE**«

Q: What is the difference between **LX160** and **LX160s**?

A: **LX160s** is a new shorter unit, version supporting the same functions.

Q: Why my **LX160s** does not receive target altitude from GPS.

A: Because there is no standard NMEA sentence which will include that value.

# 15. Appendix

## 15.1. Menu-structure

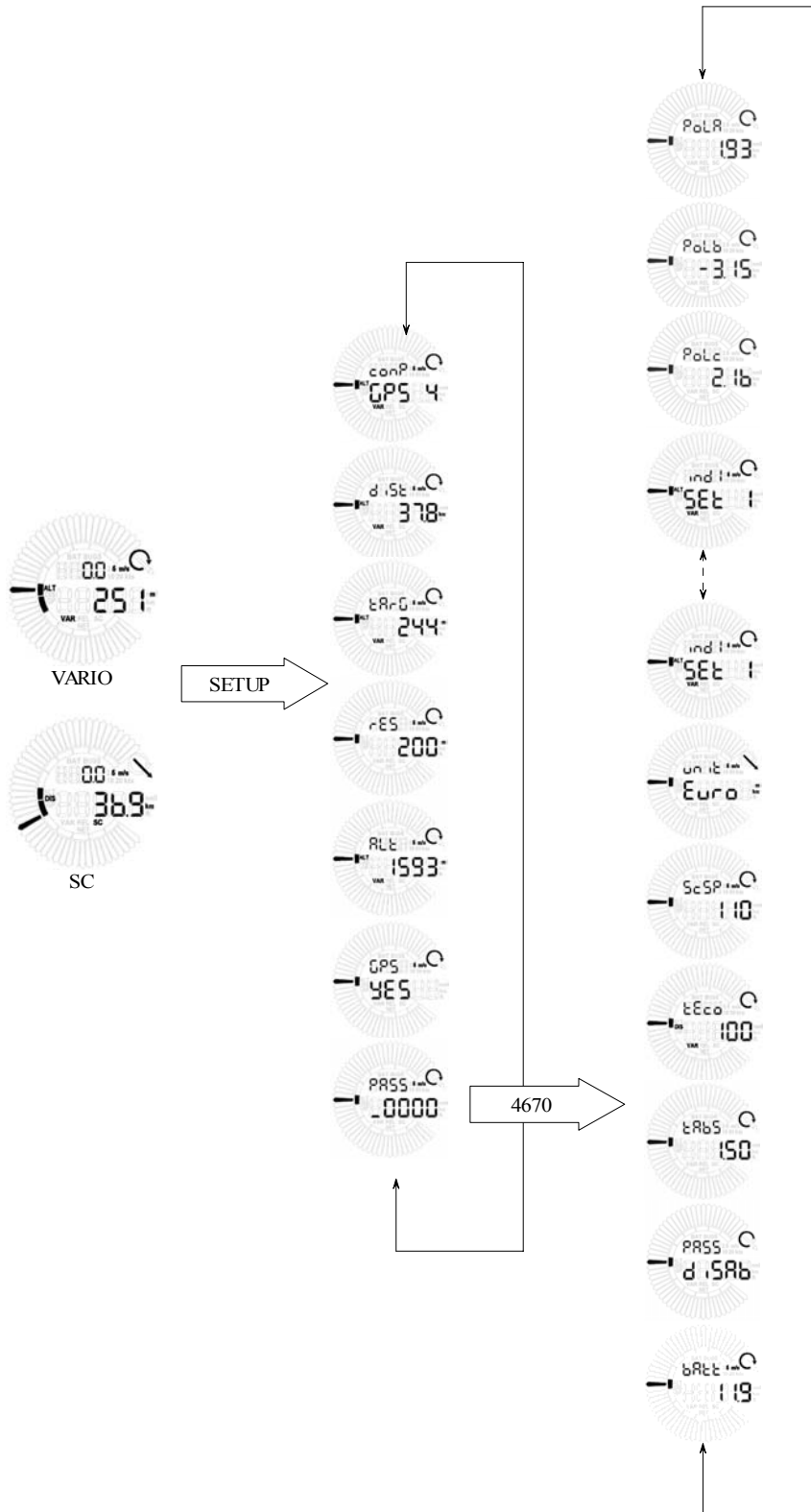

## 15.2. Wiring

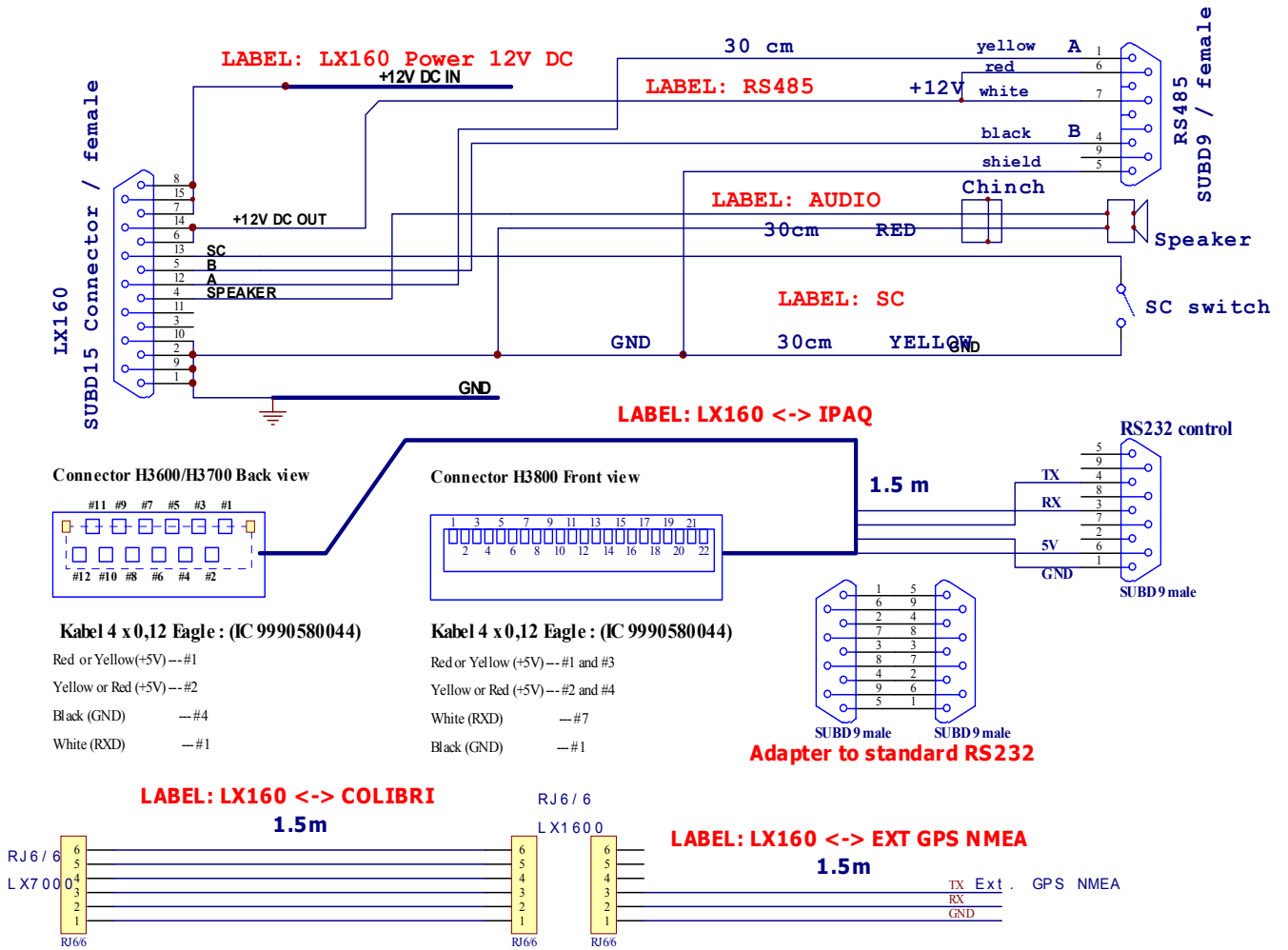

**15.3. Full connection schematic**

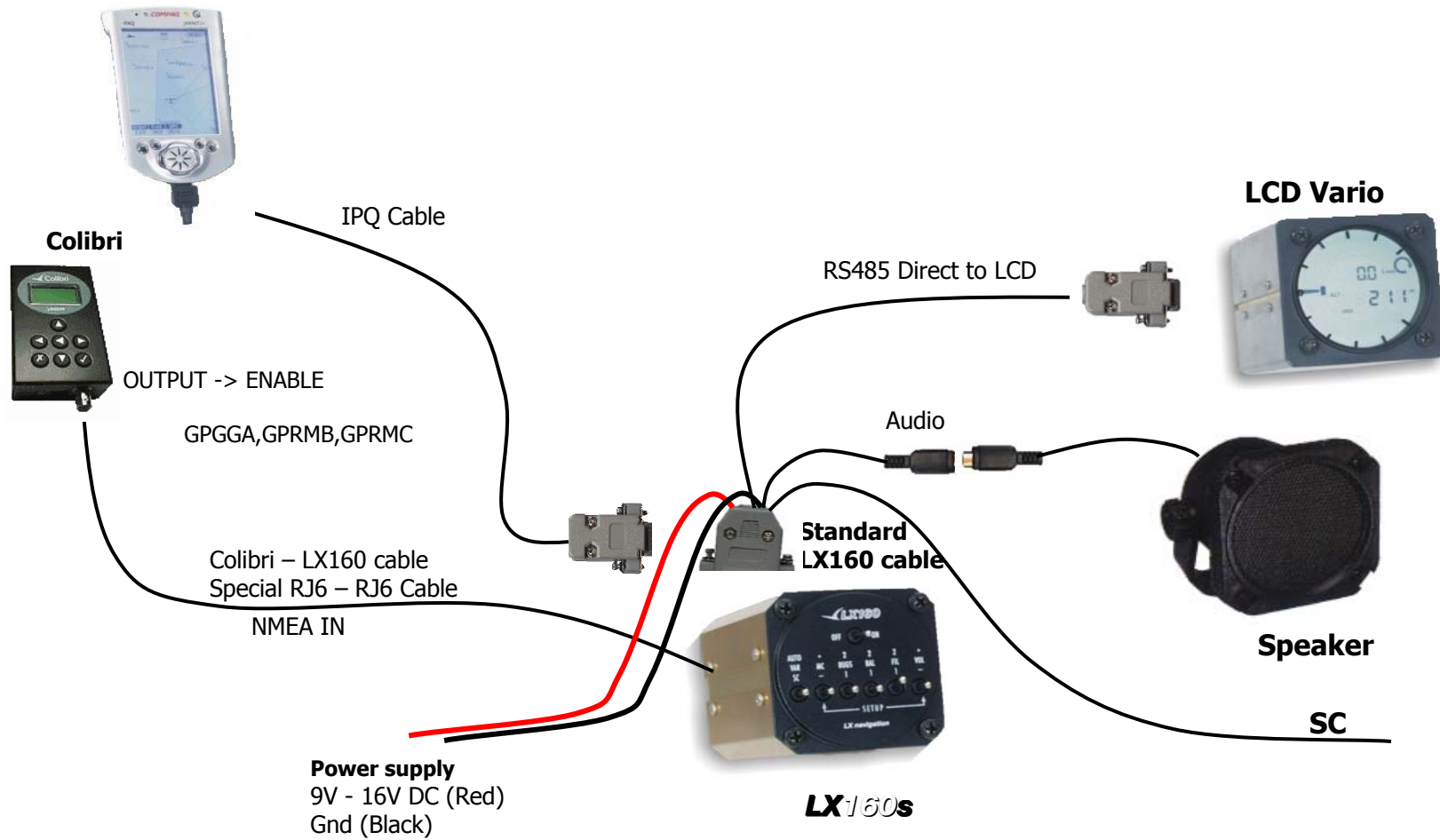

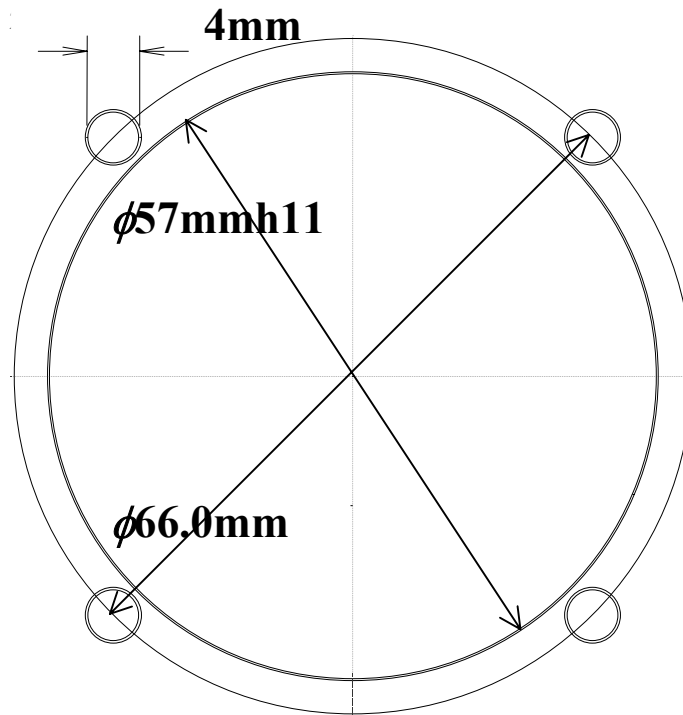
**15.4. Cut out****15.5. Pining of 15 P SUB D**

1	GND
2	GND
3	TXD
4	SPEAKER
5	RS485 B
6	+12V DC OUT
7	+12V DC IN
8	+12V DC IN
9	GND
10	GND
11	RXD NMEA
12	RS485 B
13	SC
14	+12V DC OUT
15	+12V DC IN

**15.6. Revisions**

Version	Date	Description
V3.0	01.07.2002	- new HW <b>LX160s</b>
	19.02.2003	- Full configuration schematic
V3.02	15.04.2003	- New issue
V3.03	10.9.2004	- New Issue (7, 11.8, 11.7, 11.18,15.2,15.3)
		- New wiring
		- New connection schematic

*Printed 22.11.2004*